

AMIX+ 2.0
User Manual

AMIX+ 3-channel audio & CV mixer

Thank you for purchasing this MH Eurorack AMIX+ module.

As with any Eurorack module please power off your rack before connecting.

Basic Structure

Each AMIX+ channel comprises a level control and a mute switch. The channels can be combined as a 3 channel mixer or they can be used as separate attenuators. Plugging a jack into the output of channel 1 or 2 will remove that channel from the mix and it then becomes a passive attenuator. Channel 3 can be used separately when channel 1 & 2 are removed from the mix but the channel 3 output (highlighted jack) is the mix output so if used separately it is effectively an active 'buffered' attenuator.

Moving the channel switch to the left on any channel mutes the channel whether it is being used as a separate attenuator or as part of the mix.

Jumpers

There are a couple of jumper options on the back of the module:

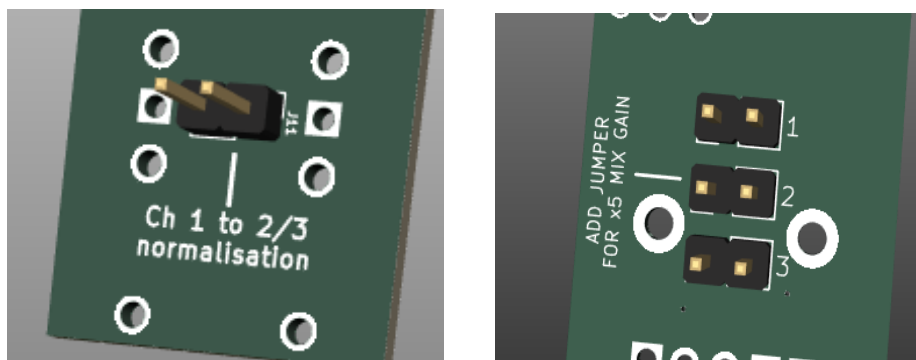

The normalisation jumper connects anything plugged in to Channel 1 to Channels 2 & 3 if there is nothing plugged in to their inputs. Insert the jumper for this option.

When jumpers are inserted for the channel gain options this boosts the mix signal for the relevant channel. Note that this gain boost is only present when the channel is connected to the mix signal. Gain Boost is not available for channel 1 or 2 when being used as a separate attenuator,

however, as channel 3 uses the mix output, gain boost works at any time for this channel. The gain boost is x5 which is enough to bring most line level signals up to the level expected by Eurorack modules.

Patch Examples

The following pages show a few examples of how the AMIX+ can be used. It's not an exhaustive list as there will be many other applications for this module!

1. VCO Mixer

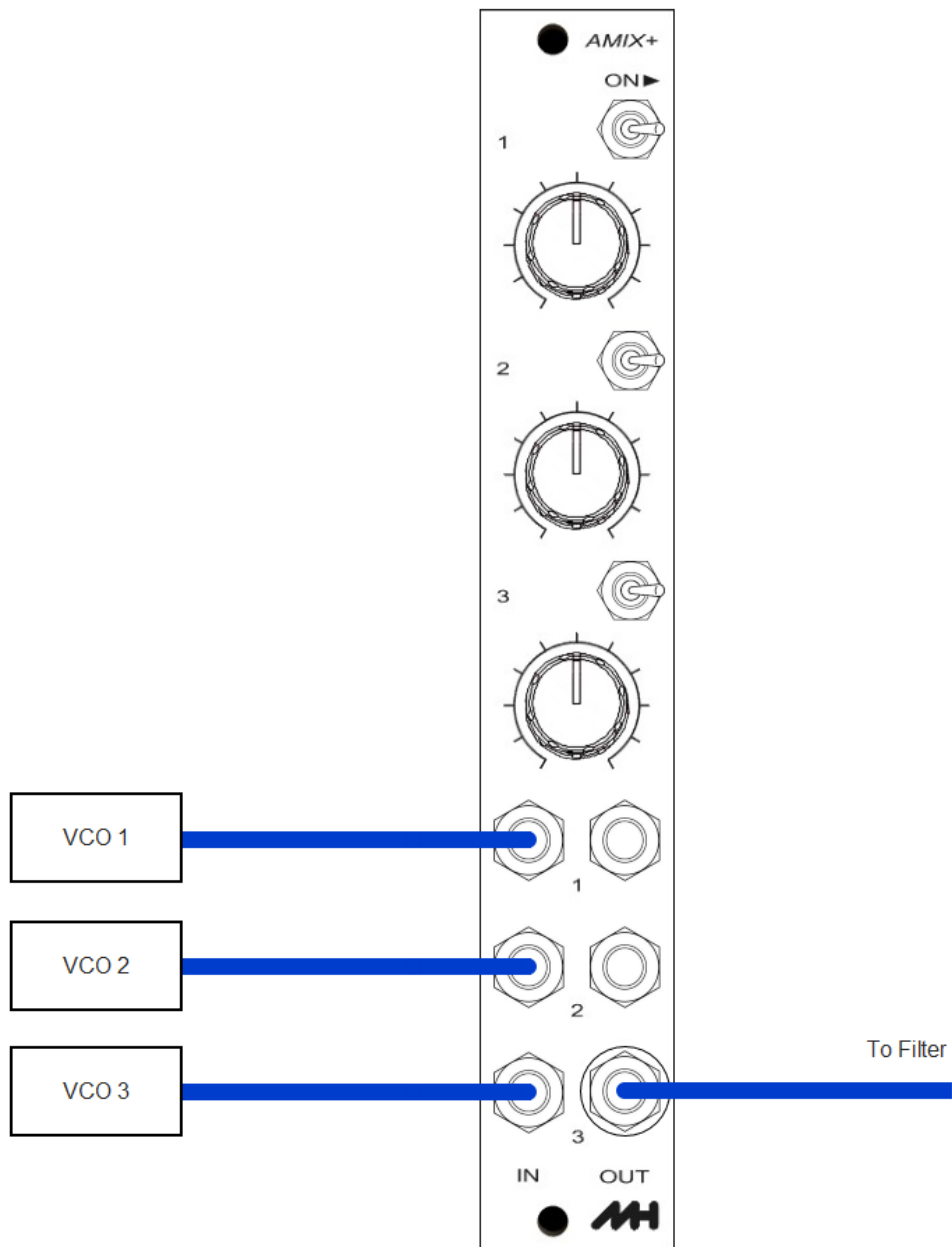

A straightforward VCO mixer with mute switches for each channel (very useful for tuning).

2. CV / Audio distribution

Requires the normalisation jumper to be inserted

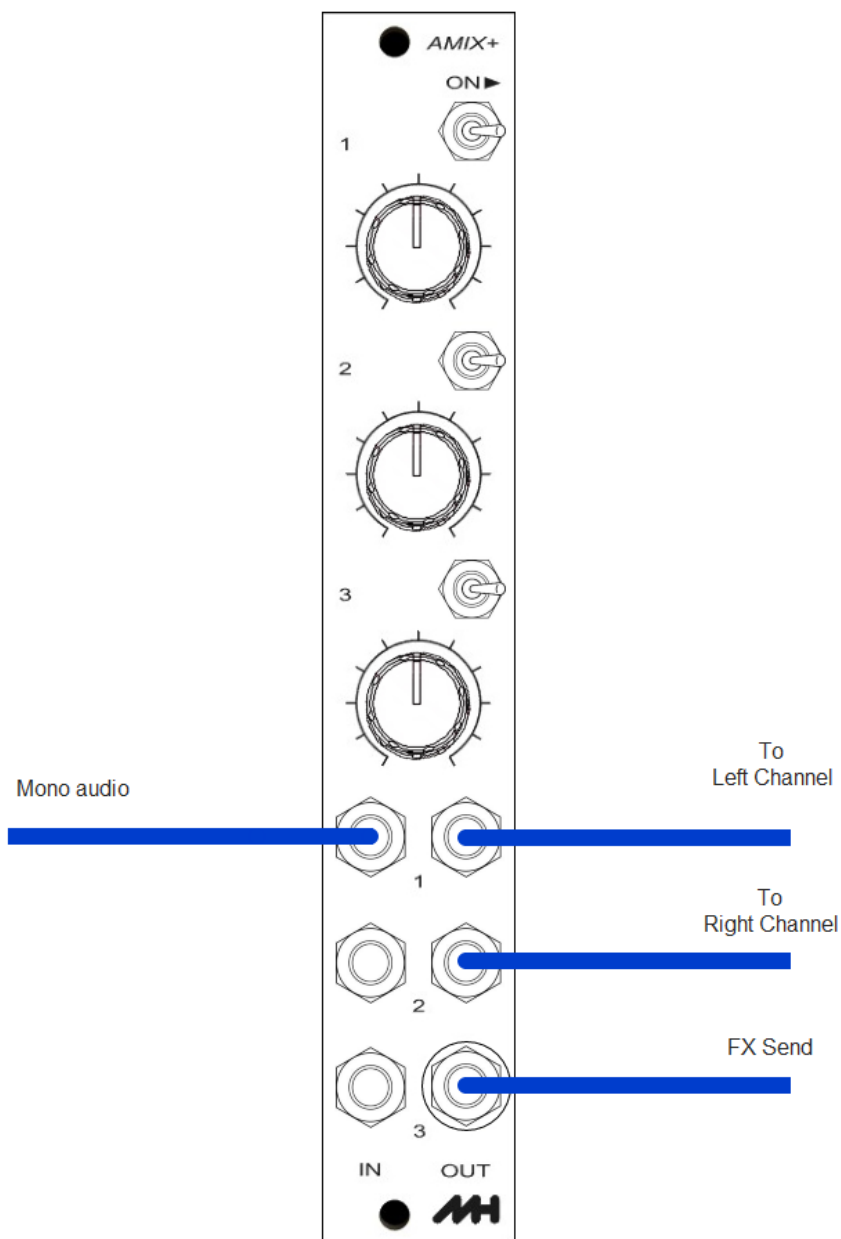

The above diagram shows an example of how a single audio source can be distributed, but this set up can be used for CV signals. For instance, sending an LFO signal to three different destinations at different levels.

3. Separate attenuation / Boost channels

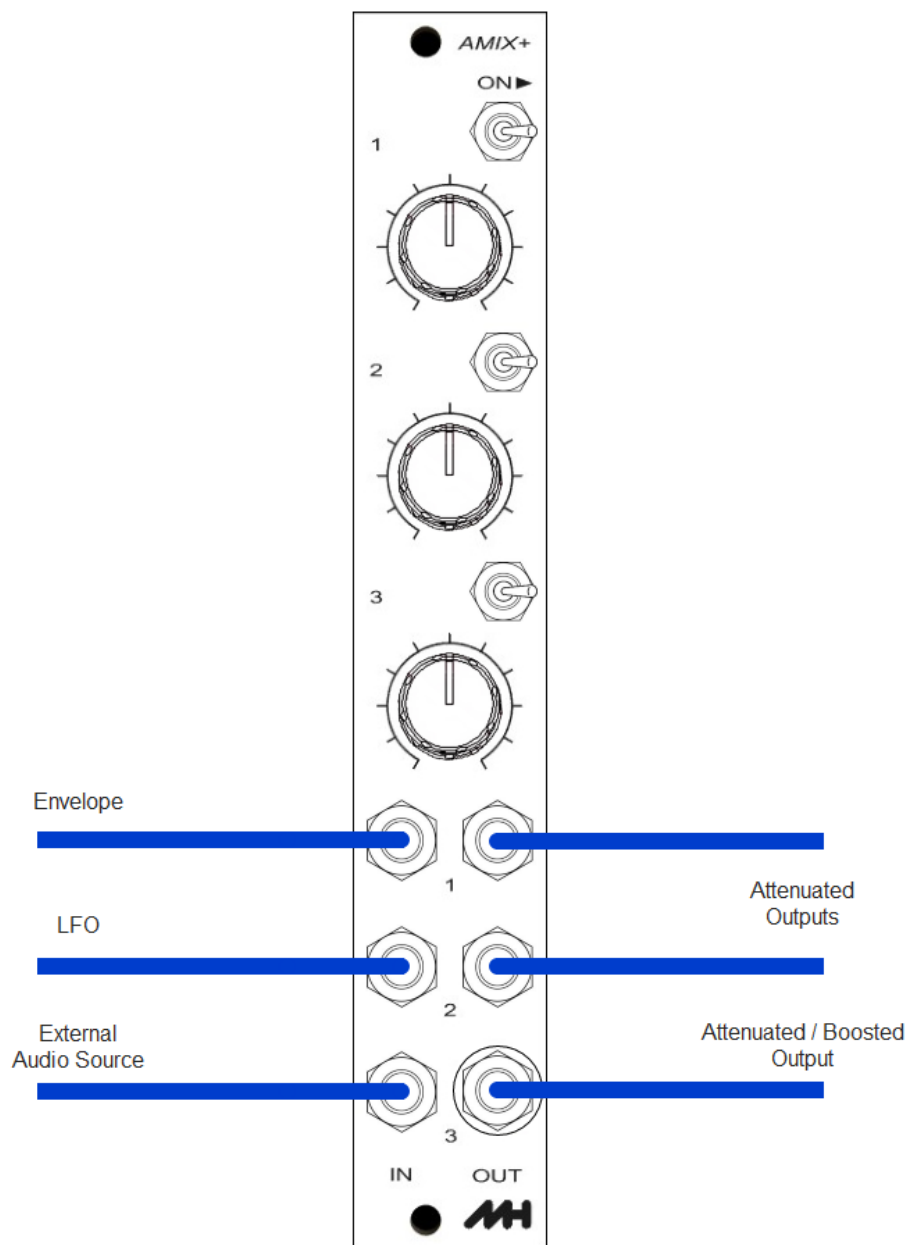

Here we show the AMIX+ being used for three separate signal paths. Note that channel 3 still has a boost option in this mode, so, for example, an external audio signal can be boosted if the channel 3 'x5 Mix Gain' jumper is in place.

4. Switched clock distributor

Requires the normalisation jumper to be inserted

Level controls should be turned fully clockwise

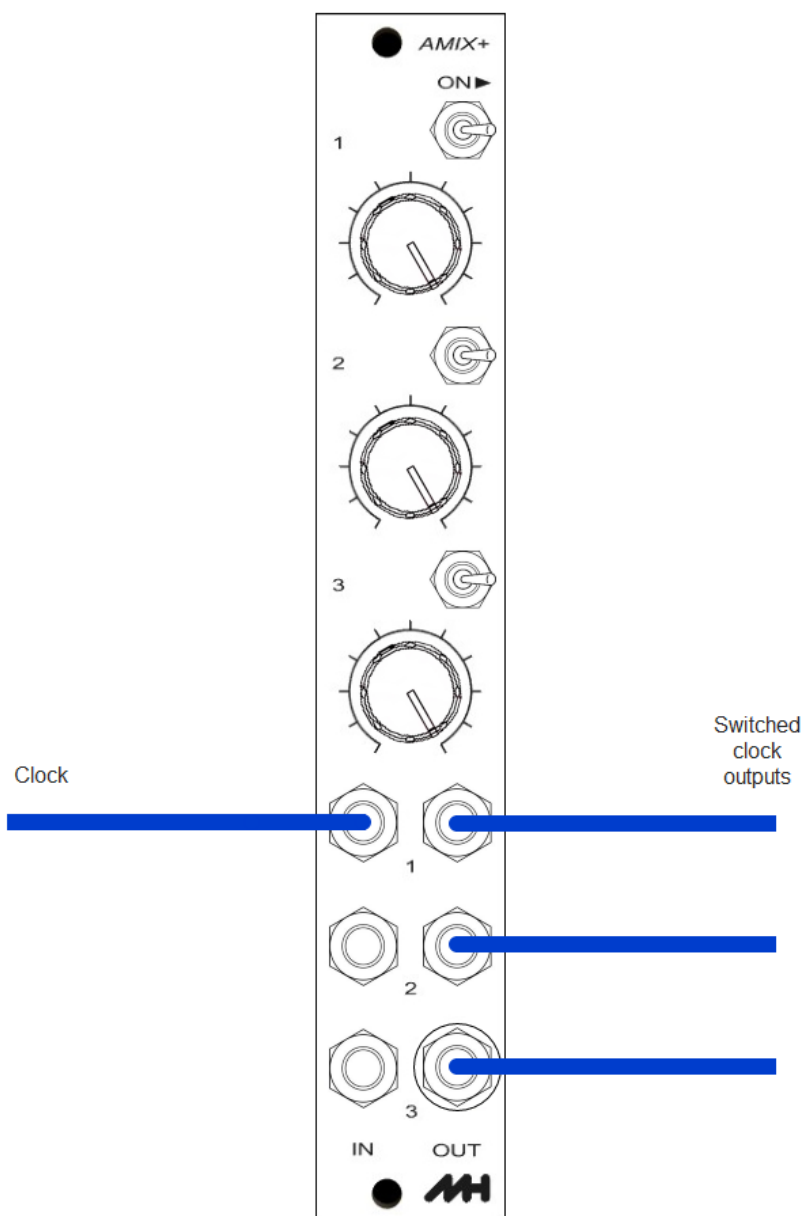

Clock signal can be distributed to different parts of your patch (eg: sequencers, drum pattern generators) and switch on and off as required.

5. Trigger pattern switching

Level controls should be turned fully clockwise

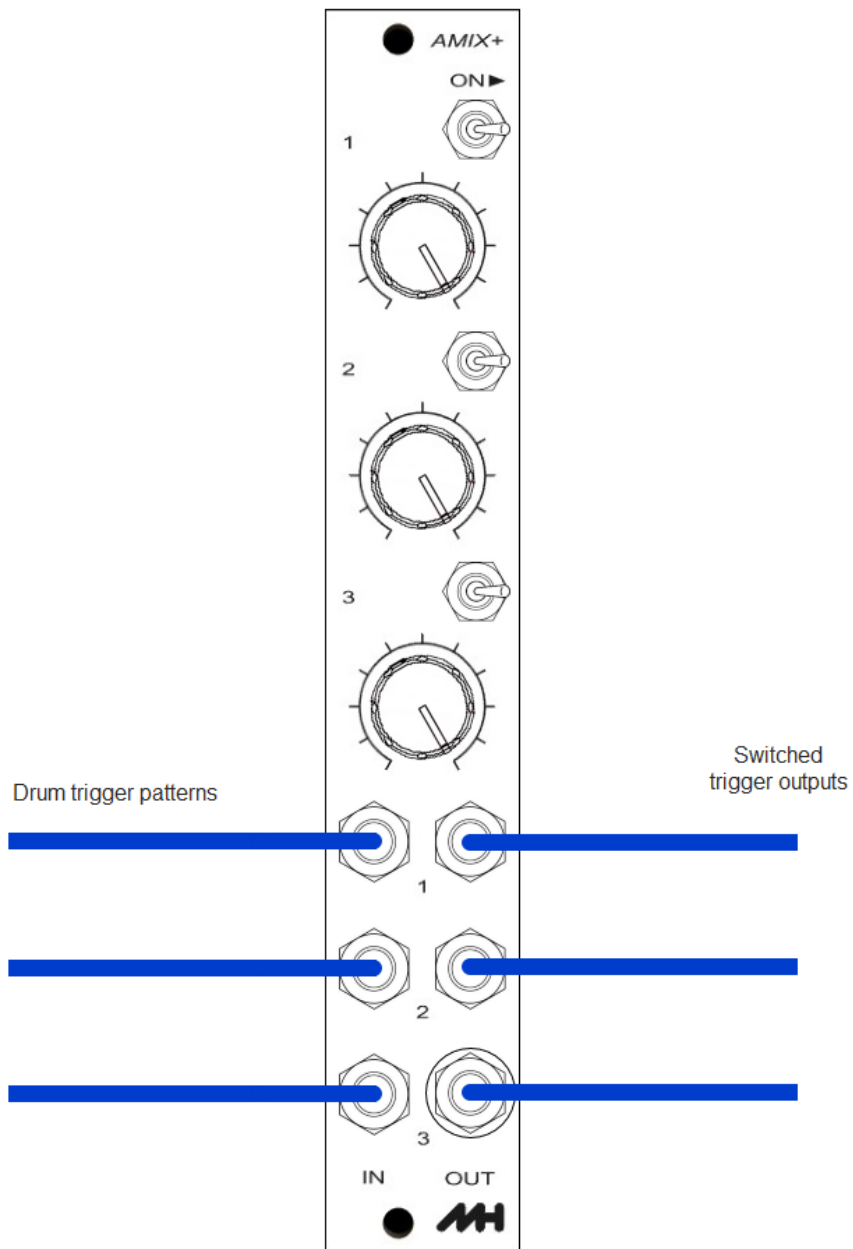

Three different trigger patterns can be switched on or muted as required.

6. Trigger pattern combining

Level controls should be turned fully clockwise

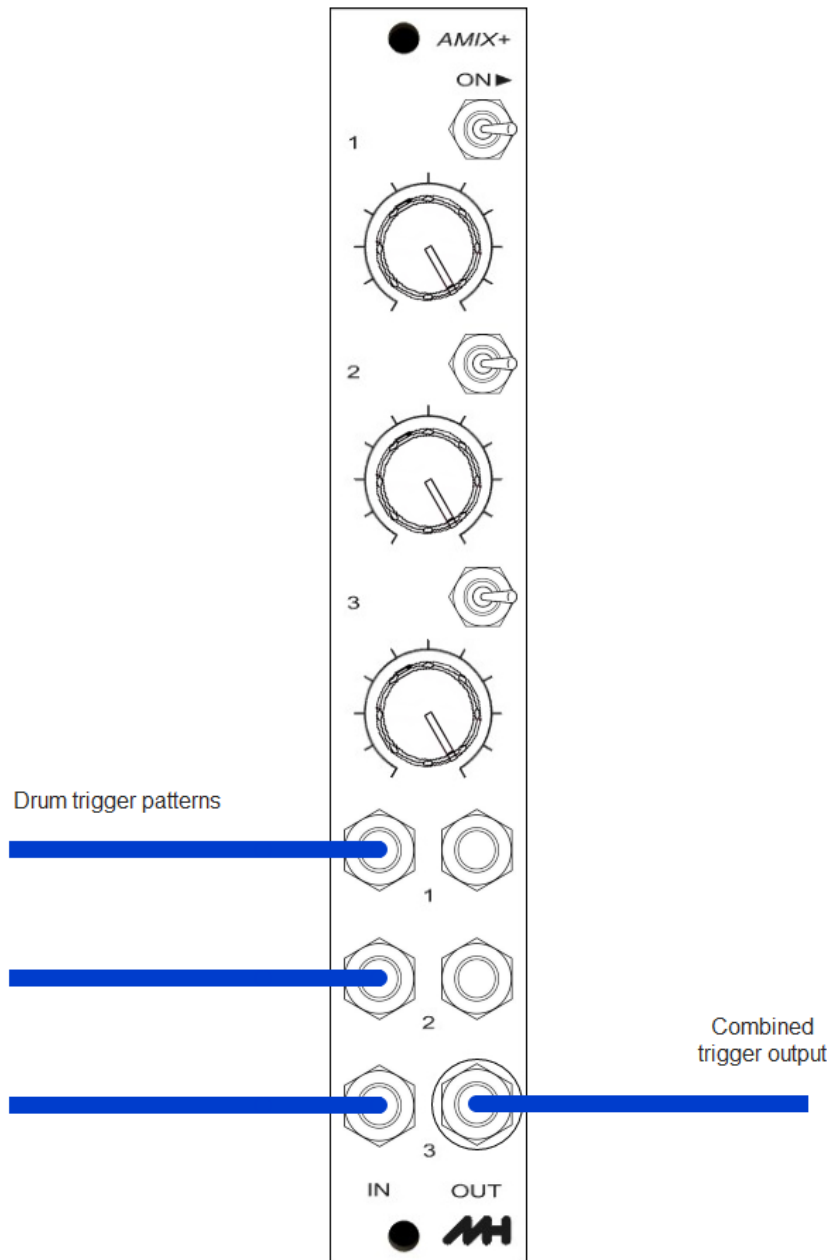

Three different trigger sources can be combined to create polyrhythmic patterns.

7. Mixed use example

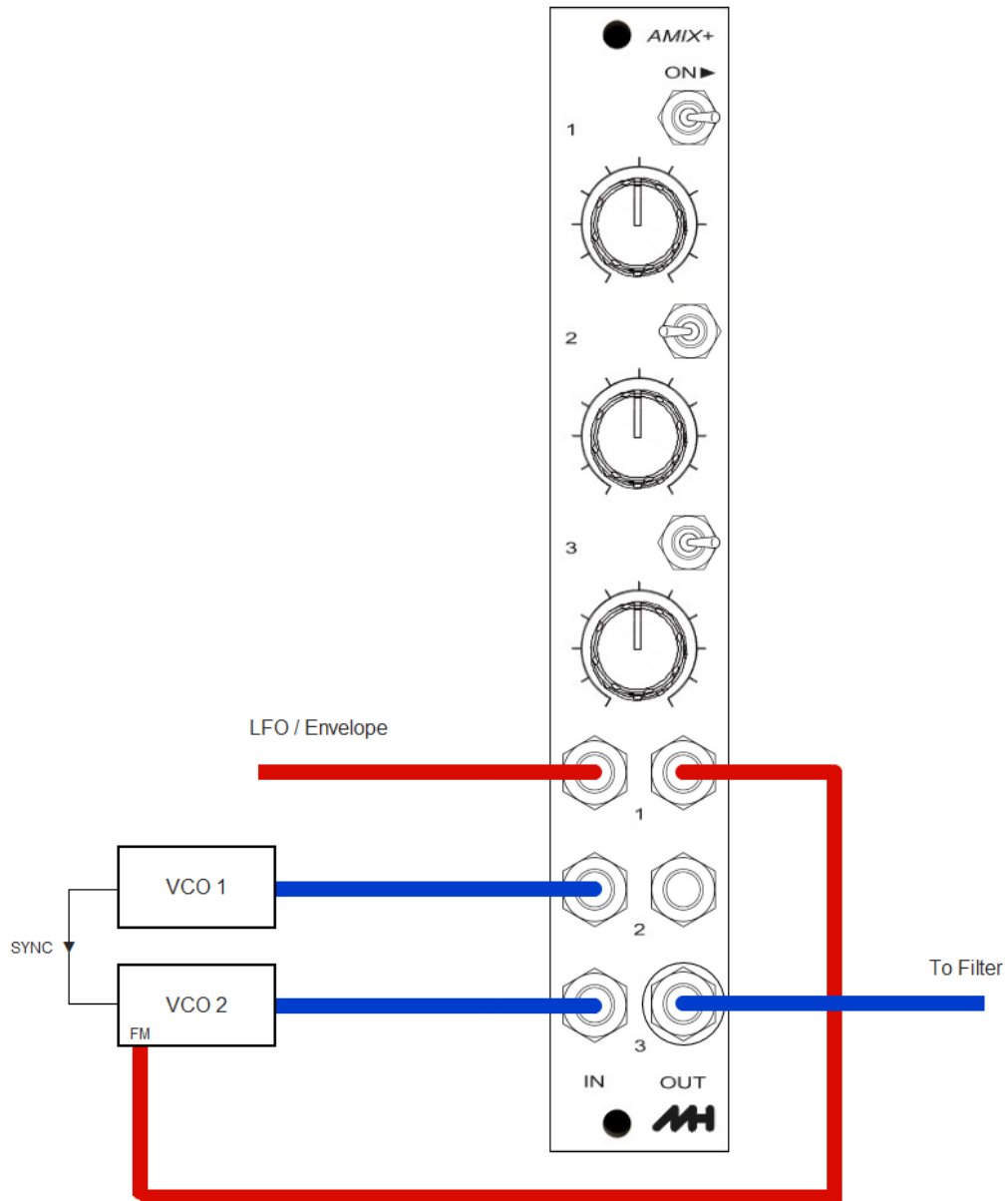

Here is just one example of combining two different functions with the AMIX+. Channels 2 & 3 act as a VCO mixer and channel 1 is an attenuator for VCO 2 FM.

The channel switches can be quite useful when switching oscillator sync on and off. (When Osc sync is off, switch off FM modulation and switch VCO 1 back into the mix)

Support

Any problems? Feedback? Please use the contact form on the [MH Eurorack website](#) :

<https://mheurorack.com/>

Follow us on Instagram:

@mheurorack

<https://www.instagram.com/mheurorack/>